

SPECIAL FEATURES

- LASER WELDED FLUSH DIAPHRAGM
- EASY FLUSHING (THROUGH FLUSHING RING)
- MOST SUITABLE FOR SLURRY, CORROSIVE & HIGH VISCOUS SERVICE
- FLUSHING RING, FLANGE & DIAPHRAGM ARE AVAILABLE IN VARIOUS
- TYPE OF SS & EXOTIC MATERIALS.

APPLICATIONS

DIAPHRAGM SEALS ARE PROVIDED IN THE INSTRUMENTS LIKE PRESSURE GAUGES, SWITCHES, TRANSMITTERS IN ORDER TO ISOLATE THE SENSING ELEMENT FROM THE MAIN SERVICE DUE TO ITS CORROSIVE, VISCOUS AND SEDIMENTED NATURE AND TO AVOID CLOGGING AND SOLIDIFICATION. THESE KIND OF SEALS ARE WIDELY USED IN THE VISCOUS & CORROSIVE SERVICES WHERE FLUSHING IS REQUIRED PERIODICALLY & FREQUENTLY.



SPECIFICATIONS

STANDARD VERSION (FOR FLANGE SIZE 1½" AND ABOVE)

(COMPATIBLE WAAREE MODELS : AC, AE, AH, AI, AL, AQ, BA, BE, BI, BJ, BO, BQ & BT)

Range	: -1 kg/cm ² 0 & 0 to 250 kg/cm ² *
Process Temperature	: -40°C to 200°C or as per fill fluid
Instrument Connection	: ½" BSP (F)
Process Connection	: Flange (As per DIN/BS/ANSI/JIS), 40 NB(1½") & above
Flange Finish	: 125-250 AARH

* Range of selected instrument shall be suitable to flange pressure rating.

Diaphragm	: AISI 316L SS
Flange	: AISI 316 SS
Fill Fluid	: Silicon Oil - DC 200
Gasket	: PTFE

DIMENSIONS - STANDARD VERSION

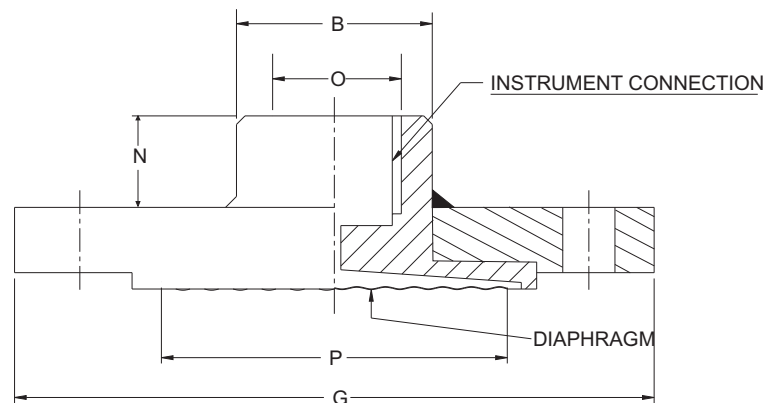

B	G	N	O	P
30	**	20	½" BSP(F)	***

** As per standard flange table ANSI, DIN, BS, JIS Etc.,
 *** 40 / 53 / 63 / 70 mm Dia. Diaphragm to suit Flange

Notes : • Drawings are not to scale. • All Dimensions are in mm.

HOW TO ORDER

Example

BASIC MODEL

CODE

DJ

OPTIONAL EXTRAS

[It is recommended that the MOC of Diaphragm & flange should be equivalent.]

INSTRUMENT CONNECTION

VM ½" NPT (F) **VL** ½" BSP (F)(Standard) **VP** 3/8" BSP (F)

XX

DIAPHRAGM

UQ TANTALUM **UR** TITANIUM **UJ** AISI 316L SS (Standard)
UL HASTELLOY 'C' **UM** MONEL

XX

FLANGE MATERIAL

TK AISI 304 SS **TN** CARBON STEEL **UH** TITANIUM **UD** TANTALUM
TL AISI 316L SS **TX** MONEL **TT** HASTELLOY C **TM** AISI 316 SS (Standard)

XX

PROCESS CONNECTION

AS PER DIN / BS / ANSI / JIS (SELECT CODE FROM FLANGE TABLE)

XXX

PROTECTION ON WETTED PARTS

VZ PTFE COATING ON DIAPHRAGM (Max. Up to 315 °C)

XX

FILLING FLUIDS (* Consult factory for specifications, price and delivery.)

US FLUROLUBE 4.2 [-45 to 175 °C] **UY** SILICON DC 704 [10 to 337 °C]
UT FLUROLUBE 6.3 [-40 to 235 °C] **UZ** SILICON DC 710 [7 to 371 °C]
UU FLUROLUBE FS-5 [-28 to 148 °C] **VA** SYLTHERM 800 [-40 to 315 °C]
UV FOOD GRADE OIL [-20 to 140°C] **VB** SYLTHERM XLT [-100 to 260 °C]
UX SILICON DC 200 [-40 to 205 °C] (Standard) **VC** HALOCARBON OIL*

XX

REMOTE MOUNTING (With capillary of Max. Up to 6 Mtrs.)

SPECIFY IN METERS (e.g. 1.5 = 1.5 METERS 2.0 = 2 METERS)

3Mtr.

CAPILLARY

PE AISI 304 SS **PG** AISI 316 SS

XX

CAPILLARY COVERED WITH ARMOUR (Applicable with PE or PG if selected)

PF AISI 304 SS **PH** AISI 316 SS **PI** PVC (Ambient Temp. Max. 60°C)

XX

OPTIONS

TB HELIUM LEAK TEST **TC** DRY SEAL ONLY WITHOUT INSTRUMENT

XX

GH MATERIAL TEST CERTIFICATES*

* MATERIAL TEST CERTIFICATES WILL BE PROVIDED FOR WETTED PARTS ONLY WITH CHEMICAL COMPOSITION TESTING. FOR OTHERS, PLEASE CONSULT FACTORY.

Refer Datasheet EE for selection of Flushing Rings.

Ordering Example: DJ - XX - XX - XX - XXX - XX - XX - 3mtr - XX - XX - XX

FOR OTHER OPTIONAL ITEMS, PLEASE CONTACT FACTORY FOR DELIVERY AND MINIMUM QUANTITY OF ORDER.

Note : Specifications and dimensions given in this product catalogue represents the state of engineering at the time of printing. Modifications may take place and materials specified may be replaced by others without prior notice.

FLANGE TABLE WITH ORDERING CODES

HOW TO SELECT

e.g. FOR FLANGE SIZE OF 1½" AS PER BS-10 TABLE E WITH RAISED FACE : C10 - A2

- A2 RAISED FACE
- A3 FLAT FACE

Flange Finish shall be 125 - 250 AARH as a standard. For other finish, please consult factory.

AS PER DIN 2527

DN	PN	CODE	DN	PN	CODE
40	6	A41	65	6	A61
	10	A42		10	A62
	16	A43		16	A63
	25	A44		25	A64
	40	A45		40	A65
	64	A46		64	A66
	100	A47		100	A67
	160	A48		160	A68
	250	A49		250	A69
	400	A50		400	A70
50	6	A51	80	6	A71
	10	A52		10	A72
	16	A53		16	A73
	25	A54		25	A74
	40	A55		40	A75
	64	A56		64	A76
	100	A57		100	A77
	160	A58		160	A78
	250	A59		250	A79
	400	A60		400	A80

AS PER DIN 2642

DN	PN	CODE
40	10	A95
50		A96
65		A97
80		A98

AS PER DIN 2633

DN	PN	CODE
40	16	A86
50		A87
65		A88
80		A89

AS PER DIN 2635

DN	PN	CODE
40	40	B05
50		B06
65		B07
80		B08

AS PER JIS - B 2210

NOMINAL SIZE	RATING /CLASS	CODE
40A	5K	B72
	10K	B73
	40K	B74

AS PER BS - 10

NOMINAL SIZE	TABLE	CODE
1½"	D	C09
	E	C10
	F	C11
	H	C12
	J	C13
2"	K	C14
	D	C15
	E	C16
	F	C17
	H	C18
	J	C19
	K	C20

NOMINAL SIZE	RATING /CLASS	CODE
50A	5K	B75
	10K	B76
	40K	B77
65A	5K	B78
	10K	B79
	40K	B80
80A	5K	B81
	10K	B82
	40K	B83

AS PER ANSI B 16.5

NOMINAL SIZE	RATING /CLASS	CODE	NOMINAL SIZE	RATING /CLASS	CODE
1 ½"	150	B33	2½"	150	B45
	300	B34		300	B46
	600	B35		600	B47
	900	B36		900	B48
	1500	B37		1500	B49
	2500	B38		2500	B50
2"	150	B39	3"	150	B51
	300	B40		300	B52
	600	B41		600	B53
	900	B42		900	B54
	1500	B43		1500	B55
	2500	B44		2500	B56

NOMINAL SIZE	TABLE	CODE
2½"	D	C21
	E	C22
	F	C23
	H	C24
	J	C25
	K	C26
3"	D	C27
	E	C28
	F	C29
	H	C30
	J	C31
	K	C32

Note : Specifications and dimensions given in this product catalogue represents the state of engineering at the time of printing. Modifications may take place and materials specified may be replaced by others without prior notice.